



User Manual



CAUTION READ THIS MANUAL BEFORE USING YOUR EQUIPMENT

Safety Instruction	1
General Information	2
Meter operation	4
Battery: Further Information and Maintenance	6
Charging.....	8
Installation Instruction.....	9
Warranty.....	13
Attachment: technical parameters.....	14
Quality Assurance	15

Thank you for choosing our products. To ensure your safety and health, please use this equipment correctly. It is important to read this entire manual before assembling and using the equipment. Safe and effective use can only be assured if the equipment is assembled, maintained, and used properly. It is your responsibility to ensure that all users of the equipment are informed of all warnings and precautions. Before each ride, especially if you may travel a long distance, inspect your e-bike.

IMPORTANT:

- Check the tires for proper inflation and cracks of the tires. Keeping the tires properly inflated and maintained will help prevent flats and damage.
- Check all cables and cable housings for fraying, breaks, rust, or corrosion and replace if necessary.
- Check the brakes to make sure that both are working properly. Additionally, check the brake pads for any damage as they will be worn over time and eventually need replacement.
- Check all nuts and bolts are taut and properly fastened to prevent injury and unnecessary wear and tear on your e-bike.
- Do not at any time dismantle or assemble any of the above e-bike components!
- Comply with local laws and regulations when riding this product. Do not ride where prohibited by local laws.
- To reduce risk of injury, you must read and follow all “CAUTION” and “WARNING” notices in this document. Do not ride at an unsafe speed. Under no circumstance should you ride on roads with motor vehicles.
- Anyone whose weight is outside the stated limits (see Specifications) is prohibited from riding.
- Use only MYATU approved parts and accessories. Do not modify your E-bike. Modifications to your E-bike could interfere with the operation of the E-bike, could result in serious injury.
- E-bike cannot be used as off-road vehicles or extreme cycling sports.
- Don't change the default speed setting of the E-bike for your safety concern. Wear a helmet and protective gear when riding.

This manual is intended as a general guide to your new MYATU e-bike and not a comprehensive reference guide. For technical support, including service, maintenance, and repair information, please contact us for more information about our e-bike.

1. About the MYATU Electric Bike

MYATU electric bike is a leading icon of e-bikes. For years, MYATU has been not only dedicating to innovation, cutting-edge technology and high-quality materials, but also providing cost effective e-bikes, to satisfy riders' various needs of transportation and even desire of exploring sports & outdoors life. Just ride freely with MYATU!

2. What's In the Box (Parts List)

Description	Quantity
MYATU Electric Bike	1
User's Manual	1
Key	2
Charging Adapter	1
Battery	1
Pedal	2
Saddle	1
Saddle Tube	1
Tools Bag	1

Note:We will decide whether to include throttle accessories in your product package in accordance with local laws and regulations.

3. Bike Components

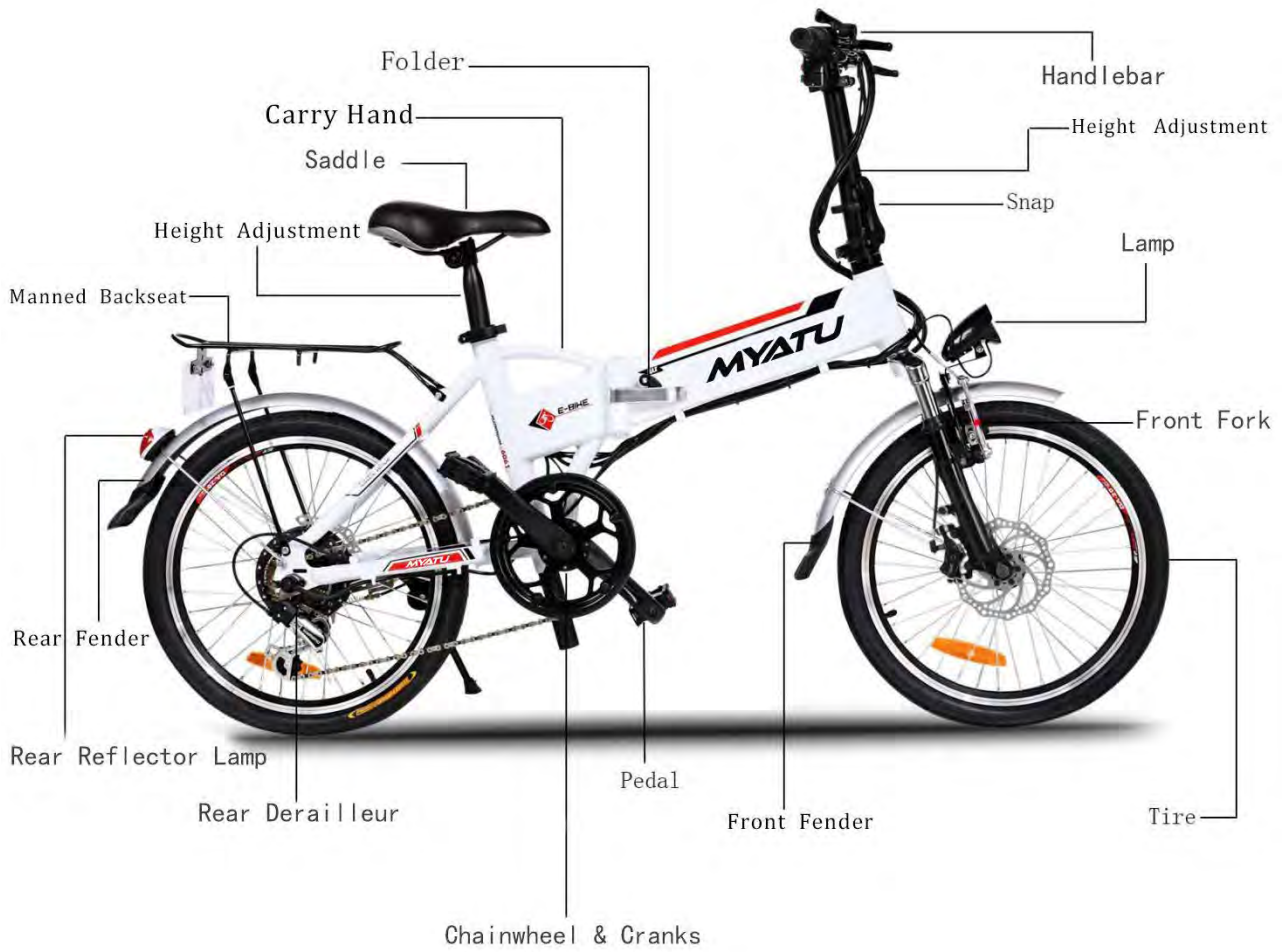

1. Meter instruction



2. Meter Operation

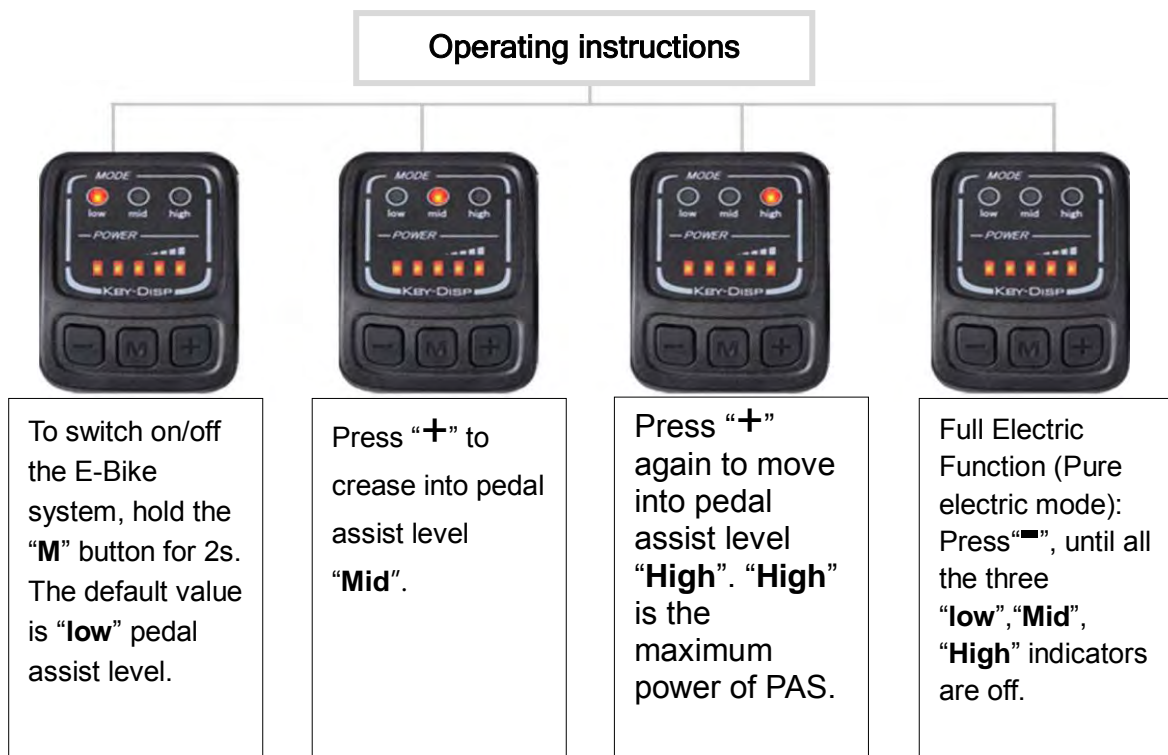

3. Operation Cautions

Be careful of the safety use. Don't attempt to release the connector when charging the battery.

- Avoid the risk of collision.
- Don't modify system parameters to avoid parameters disorder.

- How far full charge battery can go? That depends on the loading weight, road condition and battery capacity. But in the same condition, average speeds can continuous longer travel range.
- When storing the battery for a longer time, (during winter time) it is important to place the fully charged battery in a dry place.
- Attention: The battery should be re-charged once every 2-3 month when it is not used.

WARNING:

- Keep the battery out of reach for children.
- Never try to open the battery.
- Only use the MYATU supplied battery. Do not use a battery from any other different product models.
- If the battery is damaged because it has been dropped somewhere or biking accident, there may be a risk of electrolytes leakage. Beware of chemical burns! And immediately stop using the damaged battery.
- Do not touch the battery without a cloth or gloves and make sure no acid touches your eyes.
- Do not store the battery in temperatures above 95°F or below 23°F.
- Do not allow the battery to run down completely before charging. Charge the battery before storing the product. If the battery is completely empty, it may cause the battery to no longer charge.
- Charge a new battery for at least 4-6 hours before you use it in your product for the first time. Never charge the battery too long per time. Overheating or undercharging the battery may shorten battery life and decrease product run time.



IMPORTANT: BATTERY DISPOSAL

- Battery must be recycled or disposed of in an environmentally sound manner.
- Do not dispose of the battery in a fire. The battery may explode or leak.
- Do not dispose of a battery in your regular household trash.

- The RED light indicates it is in charging and GREEN light indicates the battery is fully charged. (Please put off plug from wall) Usually the charging time is 4-6 hours depends on the battery capacity remain.
- You can charge the bike directly, or you can remove the battery for charging.
- You also can take out the battery to charge it.

a. Fold the bike;

b. Turn the key;

c. Hand out the battery;

handler

key



WARNING:

- Charging time over 10 hours is prohibited please keep it away from high temperature environment and store it in a cool place.
- Please make sure that the battery charger and charging plug are always kept dry and never get wet.
- The charger should only be cleaned with a dry cloth. Never use a wet cloth, oil or any other liquid.
- Do not connect positive and negative terminals.
- Stop the charging procedure immediately if you notice anything unusual.
- It is strictly forbidden to cut the battery charging and discharging lines.
- It is strictly forbidden to disassemble the battery box or modify the internal structure and protection board of the lithium battery.
- Only use the MYATU supplied charger. Do not use a charger from any other different product models.
- After using the battery, please charge it within 12 hours.

1. When open the bike's carton box, take out E-bike and use tools to cut off the package strings.

2. Install the Handlebar.

2.1 Open the packing and full down the folding stem.

2.2 Put the stem into the folding stem.

2.3 Make the folding stem straight and adjusted the handle bar.

2.4 Adjusted the height that best suits your riding position.



3. Install Front Wheel.

3.1 Take out a protection plate of the front fork and front hub and take out the screw from the fork.



3.2 Take out the bolts and safety washer from the wheel, pull the wheel upwards and insert it in the fork drop outs then, insert the safety washers on each side and tighten bolts on each side. Use tool to tighten.



Installation Instruction



3.3 Install the fender and lamp, then use tool to tighten.



Installation Instruction



4. Install Pedal.

4.1 There is a right pedal marked “R” and a left pedal marked “L”.



4.2 The pedal marked “R” has right-hand threads. Tighten it in a clockwise direction.

The pedal marked “L” has left-hand threads. Tighten it in a counterclockwise direction (anti-clockwise). Turn the right pedal marked “R” into the right side of the crank arm, and the left pedal marked “L” into the left side of the crank arm.

Installation Instruction



- ☛ Make sure the threads of each pedal are fully into the crank arm.
- ☛ Make sure pedals are fully tightened with wrench.

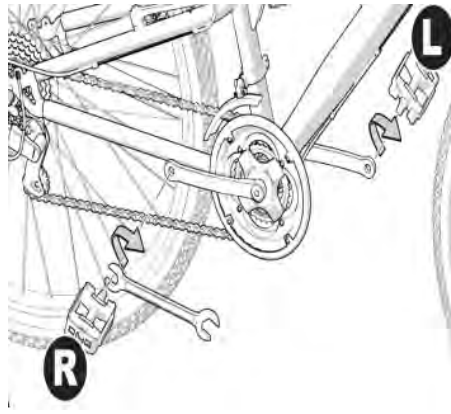

Note: Be sure to identify R/L letters on pedal's bolt when you installing.

5. Install Seat Tube.

5.1 Insert seat post into post receiver, set right its position and adjust height to fit your riding habit. Tighten seat by clamp.



6. Adjust angle of brake lever, meter, gear shifter, throttle and louder controller on handlebar, then tightens them with tools.

7. Fold the Bike

7.1 Fold the frame, turn the locker, then open quick release.



8. Change Throttle. (Make sure the throttle complies with local laws)

8.1 Take right side grip.

8.2 Install throttle, lock the throttle by tools.

8.3 Open controller box and take out controller.

CAUTION:

Controller box has 4 screws, loose them by tool, box is easy destroyed by wrong operation.

8.4 Connect the connection socket between the throttle valve and the controller.



8.5 More information, video please refer to:

<https://www.youtube.com/watch?v=8Fmb-NHRMPo&t=90s>



Year Limited Hardware Warranty

Your MYATU Electric bike includes a One Year Limited Hardware Warranty. The Warranty covers product defects in materials and workmanship under normal use. This Warranty is limited to original purchasers. This Warranty starts on the date of your purchase and lasts for one year (the "Warranty Period"). The Warranty Period is not extended if the Product is repaired or replaced.

Warranty services are provided by the e-bike. If a hardware defect arises and a valid claim is received within the Warranty Period, at its option and to the extent permitted by law, MYATU will resend new parts that are equivalent to new in performance and reliability. This Warranty is not assignable or transferable. The original purchaser may contact us for service request.

This Warranty does not cover any damage due to: improper use; failure to follow the product instructions or to perform any preventive maintenance; unauthorized repair; external causes such as accidents, abuse, or other actions or events beyond our reasonable control.

☛ Any question about the item, please contact the customer service from where you brought your device.

Attachment: technical parameters



Performance index	Project	Parameter
Basic Parameters	Vehicle Size	1560*580*1150mm
	Wheel Size	20 Inches
	Body Material	Aluminium Alloy
	Maximum Load	220 lbs (100KG)
	Vehicle Weight	49 lbs (22KG)
Main Parameters of the Whole Vehicle	Maximum Speed	15.6 mph (25km/h)
	Maximum Gradient	10 Degrees
	/	/
	Rear Derailleur	7-Speed
	Mileage Range	19~21 miles (32-35km)
	Working Temperature	14°F-113°F (-10°C~45°C)
Battery Parameters	Rated Voltage	36V
	Battery Capacity	10.4Ah
	Service Life	1000 Times
Motor Parameters	Motor Power	250W
	Motor Type	Brushless Gear Motor
	Maximum Torque	34N.M
Charger Parameters	Input Voltage	100-240V
	Input Current	1.8A
	Output Voltage	42V
	Output Current	2A

If the product has problems with the following forms during the protection period, we will provide customer service as part of the product quality guarantee.

Accessories	quality problem	Warranty period	service content
Motor	Motor will not be able to use	A year	Free delivery of parts
Accelerator	Natural conditions (such as impact force cannot be used except damage)	A year	Free delivery of parts
Controller	Failure occurs under normal use	A year	Free delivery of parts
Charger	Failure occurs under normal use	A year	Free delivery of parts
Lithium Battery	Can't charge discharge under normal use	A year	Free delivery of parts

Notes:

If the above issues occur during the protection period, please contact us and send us photos or videos of the defective parts. If we confirm that the fault is caused by the quality of the product itself, we will send you the parts that are needed replaced for free.